

**Oberlin Smith
and the Invention
of Magnetic Sound Recording**

An Appreciation
on the 150th Anniversary of the Inventor's Birth

Documents, Publications, Letters, Biographical Sketches

With an Introduction by Friedrich Karl Engel

Acknowledgments

This publication would not have been possible—and how else could it be—without much help and the friendliest assistance. I must first name James W. Gandy, Chairman of the Oberlin Smith Society, Bridgeton, New Jersey, who provided most of the documents presented here, some from the archives, some from his own compilation. A lot of suggestions and the colourful impression of Oberlin Smith's personality I am owing to the exchange of ideas with Arthur Cox and his book *Ferracute* (with Thomas Malim as co-author). Dr. William Lafferty, Dayton, Ohio, made the biographical sketches available, without which an earlier article on Oberlin Smith would have had considerable gaps. Stephen Temmer, New York, NY, helped with historical interest, commitment and organization to establish and develop contact with the friends of Oberlin Smith in Bridgeton, New Jersey.

The essay “An Inventor is Discovered” is the enlarged and up-to-date version of a publication titled *A Hundred Years of Magnetic Sound Recording*, published in the Journal of Audio Engineering Society, Vol. 36, No. 3, March 1989, pp. 170–178

Citations:

- ⁹⁹: Footnotes; on page IX
 - [99/88]: References to documents recited here; first number: page, second number: line on the given page.
 - [99]: References to sources, pages X to XI
-

Edited by
Friedrich Karl Engel
Pater-Delp-Strasse 3
D-64625 Bensheim
Germany

Copyright by the Editor

1990, January – revised version 2006, July

Content

An Inventor is Discovered	IV
A versatile engineer	IV
Electromagnetic phonograph	V
Lack of time prevents prompt patenting	VI
A sadly unsuccessful publication	VII
An Inventor is Discovered	VII
Oberlin Smith vs. Valdemar Poulsen	VIII
On the 150th anniversary of his birth	IX
Documents: Oberlin Smith and the Invention of Magnetic Recording	12
Two Great Inventions.	12
MEMORANDUM:-	12
MEMORANDUM:-	13
Certification of SAMUEL M. SHELDON	13
Letter of the Department of the United States Patent Office	14
CAVEAT.	14
Some Possible Forms of Phonograph.	16
MISCELLANEOUS NOTES.	19
The Correspondence to T. A. Edison	19
“Smith versus Poulsen”	20
CORRESPONDENCE.	22
The Development of the Talking Machine.	25
Chronology of Events	27

Between the great wars—the Civil War and the First World War—the United States of America came of age. In a period of less than 50 years it was transformed from a rural republic to an urban state. The frontier vanished. Great factories and steel mills, transcontinental lines, flourishing cities, vast agricultural holdings marked the land. (...)

“The Civil War”, says one writer, “cut a wide gash through the history of the country; it dramatized in a stroke the changes that had begun to take place during the preceding 20 or 30 years (...).” War needs had enormously stimulated manufacturing and had speeded an economic process based on the exploitation of iron, steam, electric power, and the forward march of science and invention. In the years before 1860, 36,000 patents were granted; in the next 30 years, 440,000 patents were issued, and in the first quarter of the 20th century, the number reached nearly a million.

As early as 1844, Samuel F.B. Morse had perfected electric telegraphy, and soon afterwards distant parts of the continent were linked by a network of poles and wires. In 1876, Alexander Graham Bell exhibited a telephone instrument and, within a half century, 16 million telephones would quicken the social and economic life of the nation. The growth of business was speeded by the invention of the typewriter in 1867, the adding machine in 1888, and the cash register in 1897. The linotype composing machine, invented in 1886, the rotary press and paper-folding machinery made it possible to print 240,000 eight-page newspapers in an hour. Edison's incandescent lamp lit millions of homes. The talking machine, too, was perfected by Edison, who, in conjunction with George Eastman, also helped develop the motion picture. These and many other applications of science and ingenuity resulted in a new level of productivity in almost every field.” [1]

An Inventor is Discovered

Friedrich Karl Engel

This review strikingly shows the flood of technical innovations which emerged from the USA in the last quarter of the nineteenth century. Innovations which, by tracing their development in retrospect a century later, make the history of technology so attractive. The significance which these years still have for modern times is illustrated by three inventions by three Americans from the years 1876, 1877 and 1878. Irrespective of the delays affecting each of them, these inventions heralded the most far-reaching expansion of communication capabilities since the invention of letterpress printing:

1. At the USA's “Centennial Exposition” held in 1876 in Philadelphia, PA, Alexander Graham Bell demonstrated the telephone, which he had invented and had patented shortly before [2]. This exposition marks the widespread use of this new invention, symbolizing communication over any distance without the inevitable restrictions imposed by the telegraph.

2. In December 1877, Edison filed his phonograph patent¹. This first working device of mechanical sound recording for the first time made it possible “to store up and reproduce automatically at any future time” sounds, music and speech [3]. Although initially a sensation, Edison soon rejected the phonograph “as a mere toy, without any commercial value” in favor of the development of the incandescent lamp [3]. Not until 1888 did it give rise to a device to be taken seriously when, in 1887, along with other proposals, Emile Berliner presented the “gramophone”, the ultimate form of mechanical sound recording [4]. Phonograph and gramophone initially established the technical basis for a music market still expanding today, a market in which a third medium has long participated:

3. Magnetic sound recording, developed in theory and experiment by Oberlin Smith, from Bridgeton, New Jersey, USA, in 1878. His invention had to wait even longer than Edison's for its time to come: the test reports, published ten years later (1888), went unnoticed; after twenty years (1898), another engineer was granted the first patents for this. It is then another three decades (1928) before the magnetic storage technique finds its definitive form and then develops constantly to become a universal method of storing sound, images and data [5].

In 1878, the telephone and phonograph were “high technology”. By the same token, the commercial prospects for exploiting these technical achievements were exceptionally promising. In a word, the stage was set for inventors and new inventions. Accordingly, at the beginning of April 1878, an inventive author suggested combining the telephone with the phonograph [12/23]. It is open to question whether the fact that this idea was in the air made Oberlin Smith be inspired by the article, whether he inspired it or even wrote it himself: he was working on just this at that time. The “electrical” telephone could not of course interact directly with the “mechanical phonograph”. Not least with this objective in mind, Smith developed an independent method of sound recording of a nature which could be combined with the telephone. [15/1]

A versatile engineer

Oberlin Smith was a well-trained engineer who had fortune as an inventor in unfamiliar areas—like Fritz Pfleumer, who fifty years later (1928) developed the modern magnetic tape [5]. Smith was born on March 22nd, 1840, in Cincinnati, Ohio. In 1863, he founded a plant at Bridgeton, New Jersey, and was its chief engineer until his death on July 18th, 1926 at the age of 86. At that time, *Ferracute Ma-*

chine Co. with “*Presses, Dies, and other Tools for Bar- and Sheet Metals*”, was one of the leading US shops in chipless metal working. One of its best known customers was the *Ford Motor Company*, and, especially interestingly, the *Victor Talking Machine Company* in Camden, NJ, since the foundation of this company in 1898 by Emile Berliner [4] (the *Ferracute* presses were not, of course, concerned with the manufacture of record disks [6]). Oberlin Smith applied for about 70 patents; in 1889 he was elected President of the *American Society of Mechanical Engineers*. His parents were born in England; his father was deeply committed to the anti-slavery-movement. Oberlin Smith himself later shared this commitment, and was also an advocate of women’s suffrage—clearly he was a progressive personality not only in technical matters [25/10, 25/65]. Smith obviously had the necessary technical background and there is no doubt about his qualifications.

Receptive to all technical innovations throughout his life, around the end of 1877 or the beginning of 1878 Oberlin Smith visited Edison, shortly after the latter had invented and patented the phonograph [22/64]. Smith recognized both the inventive potential of this device and its drawbacks at that time. He did not hesitate to apply his lifetime motto: “*I can make a better one*” [6] also to what was for him the unfamiliar field of sound recording; as a consequence, he purchased a phonograph and experimented with it [22/70]. As a music lover, Smith was disturbed by the scratching noises which accompany mechanical sound recording; the cost-conscious engineer had misgivings about the screw spindle, the expensive precision part which transported the cylinder along the diaphragms in Edison’s device [22/75].

The spindle can be dispensed with thus: if the outer surface of the cylinder is cut into a narrow strip, a ribbon- or wire-shaped medium of virtually any length is obtained. This is wound onto reels and transported by an inexpensive clockwork mechanism [16/46]. His first proposed improvement is as follows: changing the profile of the medium, which is to be warmed to make it easier to distort¹; a vertically modulated groove is to be made in a steel or iron strip or wire heated² by a burner, in the manner of the Edison phonograph, and the wire is to be indented in the manner of a toothed rack; i.e., the plastic pattern of the recording is to be both produced mechanically and read mechanically. Mechanically more resistant than Edison’s tin foil, the tape can be deformed more readily during the recording and sensed by a lever mechanism, which provides greater amplitudes, for playback [16/60].

Electromagnetic phonograph

Nevertheless, the unavoidable scratches remain. So how can sound waves be recorded without mechanical deformation of the medium? Smith discovers the ingenious answer in late summer, 1878 [13/13]: Changing the “magnetic profile” of the storage medium, in other words: recording by introducing an inertialess “change in state” of the information medium in the direction of its movement by a magnetic field; and, as a reversal of magnetization, playback by means of induction, that is to say scanning the magnetic field on the medium. The sound signal is stored in the form of a magnetization pattern.

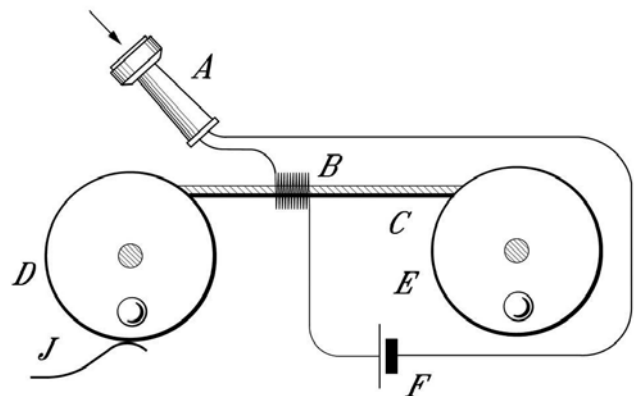

Fig. 1: Smith’s diagram of his magnetic sound recorder, shown here in the recording position. CAD reproduction from *The Electrical World* ([16/28] where it is numbered Fig. 4) with the transducer proportions corrected in accordance with his instructions in [19/24]

Smith produced a detailed description of this method ten years later [16/28]—the circumstances and consequences of this publication will be dealt with later. It is exciting to read how precisely he describes all of the basic steps in magnetic sound recording, even if sometimes, for a lack of established technical terminology, he elaborates a great deal. This shows his natural talent as a technical writer, as in his very successful books [7].

Smith’s phonograph has a straightforward design. D and E in Figs. 1 and 2 are the supply and take-up reels respectively for the sound recording medium C, and are driven by a clockwork motor (not shown); J is a rudimentary storage medium tension control; A is the “microphone”, in other words the acoustical-electrical transducer, B is the electrical-magnetic transducer (a magnetizing coil, equivalent to a magnetic head), and F is a battery which supplies the operating voltage and—not mentioned by Smith and undoubtedly not appreciated for its significance—provides DC biasing. Even as late as the mid-20th century, the IBM Executary magnetic-belt dictation system would use this circuit topology.

During recording, the audio frequency currents, “waves of varying lengths and intensities corresponding with the vibrations of the diaphragm in the telephone” [17/33], pass through the coil B and generate a magnetic field there, so that a magnetization pattern is formed on the moving sound carrier C, which reflects the sound vibrations (Fig. 1). During playback—for which, as Smith emphasizes, substantially the same components can be used as for recording—the telephone receiver A is the “loud-speaker”, the electrical-acoustical transducer (Fig. 2). The coil B, which is now the magnetic-electrical transducer, operates as an induction coil, i.e., it translates magnetization into electrical voltage. Smith sums up what his invention accomplishes:

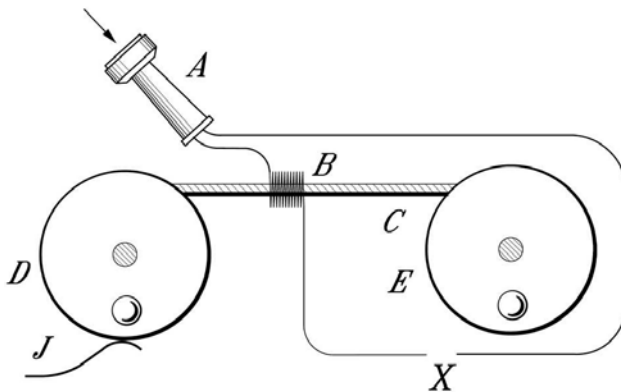

Fig. 2: Smith's diagram of his magnetic sound recorder, shown here in the playback position. CAD reproduction from *The Electrical World* ([16/28] where it is numbered Fig. 5). Transducer proportions corrected in accordance with his instructions in [19/24]. An amplifier (“intensifying apparatus”) should be inserted at X.

These waves of current will correspond in length and relative intensity with the original wave currents, and will therefore reproduce the vibrations of the original sound in the diaphragm ... at any time in the future. [18/26]

The vital words “at any time in the future” almost reproduce Edison's! The playback circuit is interrupted at X: Smith farsightedly thinks a modification here may be desirable or necessary: “... it may be possible to insert at X,... some intensifying apparatus ... but which has not yet been thought out.” [18/31]

What is the nature of the sound recording medium? Smith compensates for vague ideas about magnetism with the pioneering inspiration of cutting up fine, hardened steel wire into miniature sections. The hardening is presumably intended to increase the coercivity of steel (according to the then understanding of the nature of magnetism). In any case, hardening improves the corrosion behaviour of steel. These short pieces are embedded in a cord of cotton, silk or some other material. An additional benefit arising from this is that the magnetic properties of

the information medium can be optimized independently of the mechanical support. Smith even considered solid steel wire to be suitable, but feared that the magnetization would spread uncontrollably over the entire recording medium. If this assumption were not to be confirmed, steel wire would be “the simplest thing yet suggested” [17/74].

As regards the dimensions of the pieces of wire, Smith gives specific instructions: the clippings “must not be too short—say not less than three or four times their diameter—or they could not be saturated with magnetism” [18/42]—a consequence of the self-demagnetization of relatively short bodies³. Smith is conscious of the advantage of his sound recording medium as regards both quality—it promises to produce “a perfect record of the sound, far more delicate than the indentations in the tin-foil of the mechanical phonograph” [17/51]—and economy, namely cheapness, lightness and flexibility. Smith remains a realist, too, in his evaluation of the current state of development of his invention. Among other things, he is not sure of the necessary diameter and speed of the information medium. He has the following to say on the typical access time on recording media in an elongate format in comparison with discs or cylinders:

One disadvantage of the cord is that if some small portion of the record near the middle has to be repeated there is a good deal of unwinding to do to get at it. ... In practice, however, it might prove that this unwinding was a small matter, if a rapidly working automatic winder were used. [18/82]

Smith makes it clear that he regards the “recording telephone”, in particular, as a practical proposition. This is apparent from Fig. 3, in which the magnetic sound recorder is incorporated into a telephone circuit, and a passage from which it is only a single step to the key phrase “data protection”: a recorded telephone call could be used as evidence before a court [18/5].

Lack of time prevents prompt patenting

Smith is aware that he is adopting a promising approach independently of Edison: the method operates—at least as far as the conversion processes are concerned—purely electrically, which he hopes will produce an undisturbed recording and playback. In addition, he is certain that this method had not previously been proposed anywhere, or even suggested⁴. Rightly convinced of the significance of this invention, Smith meets with institutions to protect his invention. On September 23, 1878, he files two memoranda with the County Clerk of Cumberland,

NJ (who is responsible for his place of residence, Bridgeton). The first notes the improvements in the mechanical phonograph; the second provides a provisional description of his electrical phonograph [12/41, 13/12]. Correctly assuming that the memoranda alone could not safeguard his claims incontestably, on October 4, 1878 he filed a precisely formulated Caveat⁵ at the United States Patent Office. “A press of work” then causes a failure to act which has serious consequences: it appears that just after this Smith no longer has any time to develop this Caveat into a regular patent.

The upturn in the fortunes of his company *Ferracute* following the “Centennial Exposition”, the exhibition marking the hundred years celebration of the USA in 1876 in Philadelphia, PA, must have left the 38-year-old with no time for further experiments. No one therefore knows how long and how intensively Oberlin Smith worked on the idea of magnetic sound recording after this promising start. At the end of 1878, he wrote three letters to Edison [19/47], in which he ordered two microphones (“carbon buttons”) from Edison's telephone work; in the first letter, perhaps to disguise his intentions, he only speaks generally of “some amateur electrical experiments”. A letter of Edison's to Smith from 1882 suggests the conclusion that Smith was still working actively, although not necessarily steadily, on his recorder. In 1888, Smith writes that he has built a temporary apparatus and a functioning machine for spinning metallic dust into a cotton cord, “but was obliged to lay aside the whole thing before arriving at any acoustic results.” [18/35]

What results did Smith's experiments thus produce? Evidently, not “acoustic results” in the sense of sound signals. Should the emphasizing of “acoustic” express that Smith was somehow able to convince himself that signals were stored on his magnetic sound carrier? Did he perhaps use a circuit consisting of a battery and morse key as a “generator” to record DC pulses which were audible as crackling when played back? What practical success he could have had—given the time, equipment and financial means—can only be answered by careful experiments. One handicap, briefly mentioned in *Some Possible Forms of Phonograph* [16/25] would perhaps have defeated him: the absence of any type of amplifier.⁶

Unfortunately, most of the documents and experimenting equipment were destroyed in a fire at the *Ferracute* building in 1903; much which remained was burnt with his new home a few years after his death [8].

A sadly unsuccessful publication

Prompted by reports on further developments in magnetic sound recording [9] [10], Oberlin Smith published a complete description of his “electrical” phonograph in a 2,300 word-long article, which was printed by the respected American technical journal *The Electrical World* on September 8, 1888⁷ under the modest title “*Some Possible Forms of Phonograph*”⁸. It is astounding enough that this article obviously continued to go unnoticed; even the otherwise so alert Edison appears to have missed it. Apart from two readers' letters to *The Electrical World*, which have little to add, there seems to have been no further contemporary reaction in the USA. An abbreviated translation also appeared in France. [11]

Smith's article on magnetic sound recording was subsequently forgotten. Not until mid-1941 was “*Some possible forms of phonograph*” rediscovered, first, the article was mentioned by Dr. Semi J. Begun⁹, while he was working on his well-known book “*Magnetic Recording*” [12], and by Dr. Paul Zimmermann, a patent attorney at BASF Aktiengesellschaft [13]. Other works [14] [15] later also dealt with Smith, most of them with a rather sceptical undertone: does this article perhaps amount only to speculation? Are we dealing with a theoretical invention, in which only the present-day viewpoint can detect a creative achievement? Consequently, in the past there have been assumptions like: “*To judge from his (Oberlin Smith) technical ideas he must actually have been a physicist who took the name “Smith” as camouflage*” [15]. Smith was considered more of a far-sighted prophet than an inventor. The fact that, apart from the years of his birth and death, there were no bibliographical details on him hindered the assessment of his work enormously.

An Inventor is Discovered

It was regrettable that an informative reader's letter from Smith was not rediscovered until 1985 [16], printed by *The Electrical World* on September 29, 1888 [19/23]; the information given in this letter casts a whole new light on the subject. The most serious reservation of later readers was the conspicuous length of the coil B, which at least supposes a very high carrier speed [15]. It may also be said that this detail in the drawing shows that Smith's work was not adequately thought out.

The reservation is entirely justified; however, it can be traced to an error in the drawing. The coil B, nicely extended by *The Electrical World's* illustrator, must be quite short; taken to an extreme, even a

single winding would suffice [19/28]. A further objection: the essay reads like an armchair study, an exercise in pure theory; if Smith conducted no experiments, he can hardly be called the inventor. In this instance, Smith's letter of 1888 September 29 provides a more than adequate answer. Smith confirms a paragraph of the Caveat [14/38], according to which he also worked with an iron-core coil as electromagnetic transducer, over the edge of which the sound recording medium ran [19/33]. This not only provides proof of the experimental work, but also secures for Smith the invention of a second operational transducer. The additional data he supplies lead to an arrangement as shown in Fig. 3.¹¹

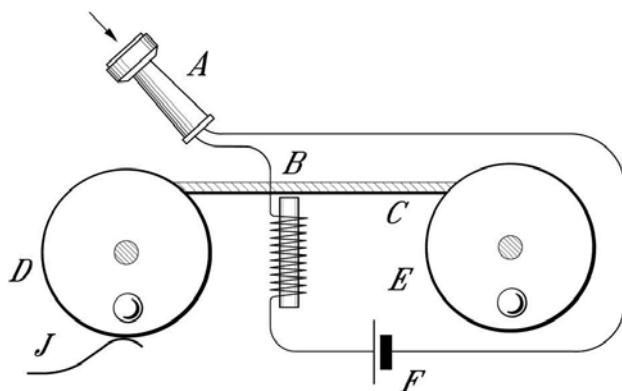

Fig. 3: Smith's diagram of his magnetic sound recorder, with the transducer redesigned in accordance with his instructions of September 29th, 1888 [19/23]

One of the principal advantages of this method was not mentioned by Smith (perhaps assumed to be self-evident), namely the erasability and reusability of the storage medium. Nevertheless, a respectable catalogue of inventions remains:

- magnetic sound recording itself,
- two operational transducers plus
- the sound recording medium in the form of wire or tape,
- the homogeneous/inhomogeneous magnetic sound recording medium.

This proves beyond all doubt that Oberlin Smith invented, not only predicted, magnetic sound recording in the true sense. His achievement is to be all the more highly rated since there were no forerunners to this method or any other invention which he could have latched onto.

It was not until 1985 that his life's work was re-discovered and comprehensively evaluated. In particular, the book *Ferracute* appearing in 1985, provides not only an abundance of historical-technical details but also key biographical information [6]. So Smith, particularly informative in this connection, even as an 80-year old,

"produced a record changer that permitted him to choose any record from among fifty and, from almost any place in his house, remove one record from the turntable, select a new record and place it on the turntable and set the needle down on the record to begin play. Smith called his device an "Autofono", and sought a patent for it in December 1921, at least four years before the first automatic record changer was available and several more years before the juke box, with its remote changer, was invented". [17]

Oberlin Smith vs. Valdemar Poulsen

So the question inevitably arises: did the Danish engineer Valdemar Poulsen (1869–1942) know Smith's work when he began with his development of the telephonograph in 1898? To obviate the misunderstandings, Poulsen, from 1898 onwards, was undisputedly the first to achieve magnetic sound recording with operational, mass-produced equipment and to demonstrate it publicly. His contribution cannot be denied [18]. His fundamental realization was that ferromagnetic bodies can be magnetized in a localized way—contrary to the conviction of his and Oberlin Smith's contemporaries that the magnetization would spread spontaneously and uniformly over the entire body, *"just as the spread of ink would obscure the words were one to write on a piece of blotting paper"* [19]. Poulsen also recognized the significance of DC bias for a distortion-free reproduction [20].

At the end of the 19th century, *The Electrical World* was considered—in Europe too—as a leading journal [21]. Without doubt, Poulsen had access to international literature, if not before then certainly since his studies. For complete information, he must also have found the Letter to the Editor of September 29, 1888. Whatever else, Poulsen knew of Smith's work as from June/July 1900, when *"Some Possible Forms of Phonograph"* was cited during the course of an unusually lengthy patent grant procedure [20/66]. Poulsen's attorney indignantly rejected this submission out of hand [20/82]. Why the examiner at the Patent Office left it at that is hard to explain, just as it is difficult to find out whether the examiner himself came upon Smith's article (maybe via the Caveat) or who drew it to his attention¹². As far as we know, Poulsen never brought himself to show due appreciation of his predecessor's work.

In the fall of 1900, Smith discovered newspaper reports [21/55] on the sensational (re-)invention of magnetic recording by Poulsen. To protect his rights (as Smith puts it, *"to have a finger in the pie of its further development"*), on November 5, 1900 he

sought the services of an attorney in New York [21/5]. Four days later, he laid claim to the invention of magnetic recording with the US Commissioner of Patents in Washington, DC—apparently without an encouraging response [21/35]. Luckily for present-day research, at the end of January 1901 Smith ordered from the US Patent Office a copy of his Caveat, by now 22 years old [14/38]. He was apparently angry that he, as someone experienced in these matters, had given away a patent which might have placed him, in the public's perception, alongside Edison and Poulsen. To be more accurate, he probably knew that he could have had Poulsen's place, as far as sound recording is concerned.

On December 16, 1908, Charles K. Fankhauser read to the Franklin Institute, Philadelphia, PA, a paper entitled "*The Telegraphone*", in which he enthusiastically and remarkably accurately describes magnetic sound recording—albeit exclusively with reference to Poulsen's work [24]. It is highly possible that Smith was present on this occasion. At least his activities immediately thereafter would suggest so: on December 23, he obtained copies of his Memoranda from the County Clerk of Cumberland [13/58]. His friends and associates Henry A. Janvier and P. Kennedy Reeves confirmed on December 24 that in 1878 they had assisted him "*in sundry experiments relating to the production of phonograph records*" [13/84].

Almost eighteen months passed by before, in October 1911, Smith took active steps, presumably for the last time, to see his work receive the recognition it was due. He wrote a detailed report [22/5] for the *Journal of the Franklin Institute*, in which he quoted the Memoranda and the Caveat from 1878. It is not clear for which specific purpose this work was intended or whether it possibly only remained as a draft. It may have been on account of this report that, in 1913, no less a figure than Emile Berliner named Oberlin Smith as the actual inventor of magnetic sound recording—and that at an event staged by the Franklin Institute (again at Philadelphia, PA), after paying a fair tribute to Poulsen's work [24/56].

On the 150th anniversary of his birth

Perhaps we shall discover by chance why Smith did nothing more than file his Caveat, which in the long run could not protect his pioneering invention under patent law. Nevertheless, we are not tracing an inventor's tragedy. In his role as engineer, producer, and salesman, Smith was very successful, even by the American standards of his day. We are left to wonder whether he regretted the generous

and far-sighted gesture with which he concluded "Some Possible Forms of Phonograph":

The writer has not ... the time, to say nothing of a properly equipped laboratory, to carry the ideas suggested to their logical conclusion of success or failure, and, therefore, makes them public, hoping that some of the numerous experimenters now working in this field may find in them a germ of good from which something useful may grow. Should this be the case, he will doubtless get due credit for his share in the matter; but if, on the other hand, these suggestions prove worthless, they will still have served a purpose, on the principle that a demonstration of what can't be done is often a pertinent hint to what can be. [19/19]

In 1990, the year in which the audio community celebrates the 150th anniversary of Oberlin Smith's birth, he has "*doubtless got due credit for his share in the matter*". There was more than just "*a germ of good from which something useful may grow*" in his ideas: he discovered what is—along with the gramophone record of his originally German compatriot Emile Berliner—the most significant method of sound recording.

Footnotes

¹ The following comment from [3] is important for assessing Smith's inventive achievement: "It is interesting ... to note that Edison never officially claimed to have invented the phonograph. His patent application was for an "Improvement in Phonograph or Speaking Machines ...", filed on December 24, 1877, and granted as titled on February 19, 1878, as U.S. Patent 200,251". The diverse prior inventions on mechanical sound recording (Leon Scott, Charles Cros) have been comprehensively presented by, inter alia, Bruch [5].

² The heating of a "sound tape provided with a wax layer" was, however, regarded as patentable in 1938 (German Patent 747,218).—Mechanical sound recording was also carried out using tape-shaped carriers, as for example in the "Tefiphon", which was on sale in West Germany until around the end of the 1950s.

³ Modern magnetic pigments are ten times as long as they are thick, due to target-oriented development. The higher the coercivity of the storage medium, the more the storage density can be increased. Acicular magnetic pigments were not developed until about 1950. Carbonyl iron (1932 ... 1936) is spherical; iron oxides Fe_3O_4 (1936 ... 1939) and Fe_2O_3 (from 1939) were initially in the form of cubic pigments. Regarding the use of a thread with included pigments, compare Smith's information with German patents 831,459 and 811,508 (BASF, 1949): filament-shaped carriers coated (not interspersed) with magnetic pigment.

⁴ compare Footnote 1!

⁵ Caveat, from the Latin, let him beware. A Caveat (under statutory regulations in effect up to about 1907) is filed in the patent office. The principal object of filing it is to obtain for an inventor time to perfect his invention without the risk of having a patent granted to another person for the same thing. In practice of patent law, a caveat means a legal notice serving the purpose not to issue a patent of a particular description to any other person without allowing the caveator (one who files a caveat) an opportunity to establish his priority of invention.

⁶ This detail shows how far Smith's proposals were still ahead of their time. Even Poulsen's "Telegraphone"—some of which used steel wire, others steel tape—ultimately failed for lack of amplification equipment, which was not available until after 1910, by which time the Austrian Robert von Lieben had developed the vacuum tube, invented by the American Lee de Forest, into the low frequency amplifier [R. von Lieben, E. Reisz and S. Strauss, German Patent 249,142 (1910 Dec. 20)]

⁷ By an incredible chance September 8th, 1888, also saw a publication of great significance in the light of later events: the engineer Herman Hollerith's first two patents relating to punch cards for analyzing censuses and similar data. These studies are regarded as the origin of modern data processing. Herman Hollerith, of German origin, enjoyed quicker and greater success than Oberlin Smith: his counting and sorting machines were successfully used for the American national census as early as 1890. The results of the census were published only with reluctance, because the population of the growth-conscious USA had increased since 1880 not by 30%, as was naturally assumed, but "only" by 25%. [H. Zemanek, "Hollerith und Schäffler—Datenverarbeitung um 1890, Drei Nationen werden elektrisch gezählt" (Hollerith and Schäffler—Data Processing around 1890, Electrical Censuses in Three Nations), in *Elektrotechnik im Wandel der Zeit* (Electrical Engineering over the Years), H. A. Wessel, Ed. (VDE-Verlag, Berlin/Offenbach 1986), p. 96]. Magnetic tape storage and data processing successfully merged in the early Fifties. [E. Rasek, *Über die historische Entwicklung der Datenspeichertechnik auf Magnetband* (On the history of digital data storage on magnetic tape), *Elektronische Rechenanlagen*, vol. 27, 4/1985]

⁸ Smith casually also adds a third proposal here: Changing the "resistance profile" of the storage medium, in other words its galvanic conductivity, which is produced mechanically and read electrically (elements of the carbon microphone principle applied to sound recording), i.e., the recording forms a resistance pattern [18/96].

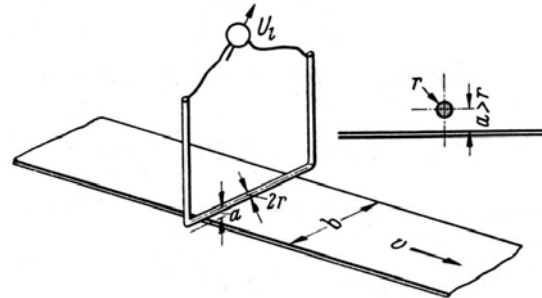

Fig. 4: Single-turn transducer for magnetic tape scanning

⁹ In the 1930's, Dr. Begun, while working for C. Lorenz in Berlin, designed among other things the "Stahlton-Bandmaschine" (steel tape magnetic recording machine), the unjustly forgotten predecessor and competitor of the "Magnetophon", the present-day analog tape recorder. From 1944 onwards, in the USA, Dr. Begun constructed the "Soundmirror" tape recorder, independently of the German development of the Magnetophon, and many of these were sold by the Brush company. It was mass production of the audio tapes for the "Soundmirror" which gave US manufacturing its foothold in magnetic storage technology.—A comprehensive description of the "steel tape era", particularly the simultaneous, independent development of the Marconi-Stille tape recorder and Dr. Begun's Steel Tape Sound Recording Machine, will be found in

- W. Ch. Lafferty, "The Early Development of Magnetic Sound Recording in Broadcasting and Motion Pictures", Ph.D. Dissertation, Evanston, IL, 1981
- W. Ch. Lafferty, "The Use of Steel Tape Recording Media in Broadcasting", SMPTE J., pp. 676—682 (1985 June)

¹⁰ Modern literature names the single-turn transducer (Fig. 5) as the physically simplest method of scanning a magnetic tape. [O. Schmidbauer, "Vorgang der Magnetton-Aufzeichnung und Wiedergabe" (Magnetic Sound Recording and Reproduction), in F. Winkel (Ed.), *Technik der Magnetspeicher* (Magnetic Storage Technology), 1st ed. (Springer, Berlin 1960), p. 48

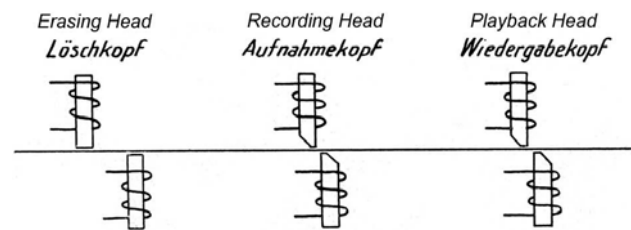

Fig. 5: Design of the magnetic heads in the "steel tape magnetic recording machine"

¹¹ This arrangement bears a great resemblance to the transducer configuration (Fig. 5) used in the 1930s to scan magnetic steel tape recordings [H.-J. von Braunmühl, "Der heutige Stand der Schallaufnahmetechnik und ihre Anwendung beim deutschen Rundfunk" (The present state of sound recording technology and its application in German Radio), *Akust. Z.*, pp. 250 ff. (1938)]

¹² This patent—USP 661,619—has a remarkable history. It culminates in 1903, when a private law was necessary since more than 7 months had elapsed between application (1889, Aug. 8)

and grant of the patent (Nov. 13, 1900). It has still not been explained today why USP 822,222 (1906) uses the same drawings as 661,619, but includes 43 claims instead of just 4 [Personal communication with St. Temmer, New York, N.Y.]—In this context, the “*virtually incredible intrigue surrounding the corporate lifetime of American Telegraphone Corporation*”, a company founded by Poulsen in 1903, must also be recalled. Even a “*Hearing before the Committee on Patents, United States Senate*” (1932) does not appear to have brought any clarity into the matter of the strange business conduct of this company. [W. Ch. Lafferty, “*The Early Development of Magnetic Sound Recording in Broadcasting and Motion Pictures*”, Ph.D. Dissertation, Evanston, IL, 1981, pp. 20—25]

References

- [1] Olson, Gray, Hofstadter, Endsley (editors): *An Outline of American History*; International Communication Agency / Embassy of the United States of America; pp. 95-96
- [2] U.S. Patent 174,465, Febr. 14, 1876
- [3] W.W. Welch, *Edison and His Contributions to the Record Industry*, vol. 25, pp. 660-665, J. Audio Eng. Soc., Nov./ Dec. 1977
- [4] E. Hutto jr., *Emile Berliner, Eldridge Johnson, and the Victor Talking Machine Company*, vol. 25, pp. 666-673, J. Audio Eng. Soc. (October/November 1977)
- [5] H. H. K. Thiele: *Magnetic Sound Recording in Europe up to 1945*; J. Audio Eng. Soc., Vol. 36, No. 5, May 1988
- [6] Arthur J. Cox and Thomas Malim: *Ferracute: The History of an American Enterprise*, Bridgeton, N.J., 1985, p. 123; in the following abbreviated as “Ferracute”
- [7] as an example: O. Smith, *Press-Working of Metals* (John Wiley & Sons, New York, NY; London, Chapman & Hall, 1904)
- [8] Ferracute, p. 111
- [9] Ch. S. Tainter, *The Graphophone*, *The Electrical World*, July 14, 1888
- [10] N. N., *The Improved Gramophone*, *The Electrical World*, August 18, 1888
- [11] Wetzler, J., *Le Phonographe*; La Lumière Électrique (The Phonograph/The Electric Light), vol. 29, 1888, pp. 592—594
- [12] S.J. Begun, *Magnetic Recording* (Rhinehart, New York 1949), p. 2
- [13] P. A. Zimmermann, “*Oberlin Smith, ein vergessener Erfinder*” (Oberlin Smith—a forgotten inventor), *Die BASF*, House magazine of BASF AG, p. 146 (1957). In a review dated “June 1948”, on the development of magnetic sound recording, Zimmermann already reports on *Some Possible Forms of Phonograph*.
- [14] J. Klinkmüller, “*Zur Geschichte der elektromagnetischen Schallaufzeichnung*” (On The History of Magnetic Recording), *Elektrotechn. Z. A*, Volume 76, No. 3, pp. 48—50 (1955).—K. speculated, on the strength only of an advertisement for “magnet wire” which appeared in *The Electrical World* in 1888, that functional equipment based on Smith’s principles already existed at that time. The fact that “magnet wire” means something like insulated copper wire for the winding of coils and the like is revenge for K having broken off a literal quotation before the phrase “before arriving at any *acoustic* results” [18/34].
- [15] W. Bruch, *Von der Tonwalze zur Bildplatte* (From Sound Cylinder to Video Disc), Part 2; Franzis Verlag, München, 1983, pp. 9—14
- [16] F. Engel, *A Hundred Years of Magnetic Sound Recording*, J. Audio Eng. Soc., Vol. 36, No. 3, March 1986, pp. 170—178
- [17] Ferracute, p. 114
- [18] Three of the numerous patents granted to Poulsen:
- *British Patent No. 8961*, Apr. 28, 1899: Method of and Apparatus for Effecting the Storing Up of Speech or Signals (Cylinder with helical steel wire; Steel band <sic>; insulating material such as paper covered with a magnetizable metallic dust)
- *United States Patent No. 661,619*, Nov. 13, 1900: Method of Recording and Reproducing Sounds or Signals (steel wire which is spirally wound on a drum)
- *United States Patent No. 789,336*, May 9, 1905: Telegraphone (wire which is wound back and forth from one reel to another, electric motors being utilized to drive the spools)
- [19] *Poulsen’s Telegraphone*, illustrated publicity brochure, “Copyright 1907, W.S. Edwards”, p. 6
- [20] USP 873,083, Dec. 10, 1907, Pedersen and Poulsen
- [21] *Elektrotechn. Z.*, March 1889, page 169
- [22] Charles F. Fankhauser, *The Telegraphone, The principles embodied in it, its accomplishments in actual experience, and its influences on our commercial and social life*, paper presented on December 16, 1908; printed in *The Journal of the Franklin Institute*, Vol. CLXVII, January 1909, pp. 37—46

Documents: Oberlin Smith and the Invention of Magnetic Recording

N.N., *The Bridgeton Chronicle, Bridgeton, N.J., Friday, April 5, 1878; excerpts.*

Two Great Inventions.

(...) These two inventions (*Telephone and Phonograph*), the one probably having suggested the other come to us at the beginning of our second American century as the astonishing forerunners of still greater wonders yet to be given to the world.

(...) At Prof. Arnold's lecture the other evening, in New York, the Phonograph machine repeated the words spoken to it loudly and clearly, so that every person in a large hall heard and understood what was said. When the apparatus is yet further perfected, as no doubt it will be, the tone will be less metallic than now and they will have greater volume and power. Besides bottling up the songs and speeches of our celebrities for future use, we may be able to attach a Phonograph to the light houses on our coast and by loud and repeated utterance of a few words during the darkness of the night, warn off the endangered vessel. A combination of the two great inventions may, in time, make it a common experience for one to send a message by Telephone and preserve it by Phonograph, so that although there should be no one in the office when it is received, on the arrival of the operator or the person for whom the message is intended, it could be secured.

30

Oberlin Smith, Memorandum (I: Heat Phonograph), Sept. 23, 1878. Original re-discovered by James W. Gandy on October 18, 1988.

OBERLIN SMITH, President
FRED F. SMITH, Sec. and Treas.
OFFICE OF THE FERRACUTE MACHINE CO.

Foot and Power Presses, Dies, and all other fruit Can Tools:
Special Hardware Drilling Machines: Pipestocks and Dies.
Bridgeton, N. Jersey, Sept. 23, 1878.

MEMORANDUM:-

In April last --- about the 30th. -- I invented an improvement in talking phonographs, thus:-

A, mouth piece & diaphragm, with spring and indenting needle as in the Edison machine. B, reel of thin ribbon, E, of iron, steel or other substance capable of being softened by heat, temporarily. C, reel on which to wind it by clock work or by other means. D, supporting roller (or stationary bar) with a flat groove the width of E, and a v groove in the bottom of it for the needle to

75

indent into -- see section through axis in fig. 2. F, a heating lamp. This is the "receiver". E, being soft when hot, receives the indentations easily as tin foil, or more so. It cools by the time it gets on reel C, and is much harder and more durable than tin foil. The same apparatus can be used as the "talker", as in Edison's, but the great advantage of having the indented ribbon of hard substance is that in the "talking" diaphragm, G, the vibrations may be augmented in amplitude by means of a lever H, the ribbon E being hard enough not to lose its form by the increased pressure due to the leverage as tin foil would do.

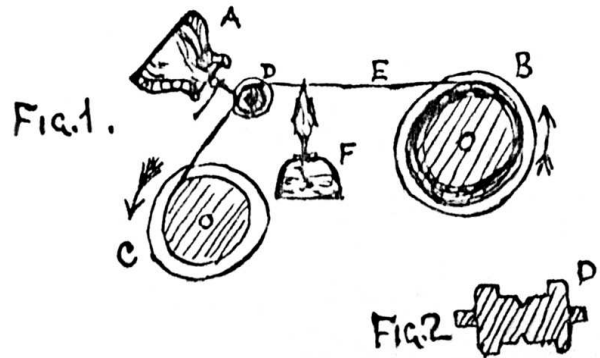

The chief advantages of this form are 1st. the loudness of voice produced by the increased amplitude of vibration. 2nd. simplicity and cheapness of construction of the whole machine -- requiring no accuracy in "registering" devices, beyond having the groove in D to about fit width of E. 3rd. the cheap material of which E may be made. 4th. durability of E, even with much repeated use.

65

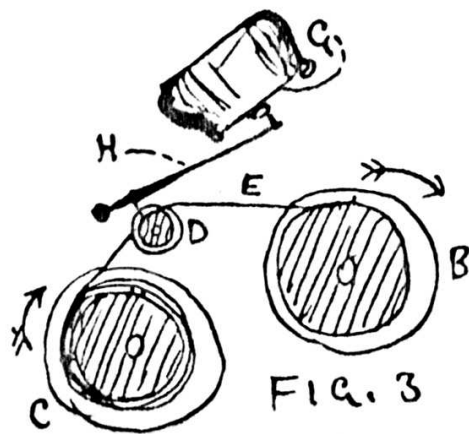

5th. Convenience and freedom from injury in handling and transporting E -- when wound on reels, or spools, like thread. E would -- if of iron or steel probably be about 1/20" wide & 1/200" thick.

70

I mentioned this invention to Messrs. Fred F. Smith & P. K. Reeves within a few days of its conception. Of

75

course its use is subject to some of the claims of Edison's patent.

Oberlin Smith.

We remember the above being described to us.
Fred F. Smith. P. Kennedy Reeves.

*Oberlin Smith, Memorandum (II: Electrical Phonograph),
Sept. 23, 1878. Original re-discovered by James W. Gandy
on October 18, 1988*

OBERLIN SMITH, FRED F. SMITH,
President OFFICE OF THE Sec. and Treas.
FERRACUTE MACHINE CO.
Foot and Power Presses, Dies, and all other fruit Can Tools:
Special Hardware Drilling Machines: Pipestocks and Dies

Bridgeton, N. Jersey, Sept. 23, 1878.

MEMORANDUM:-

I have invented another improvement in talking phonographs, and described it to Mr. Fred F. Smith. (That's so, Fred F. Smith). It is, however, subject to experimental investigation of the capability of a small wire (probably tempered steel) to receive magnetism (by induction from an electrical current in a short surrounding helix) in spots or zones of varying intensity at different portions of its length.

Assuming this capability, my "receiver", or "listener", is as follows: - A, Mouthpiece, diaphragm, carbon button &c. of an Edison telephone. B, C, reels for moving wire, E, through helix D. F, battery.

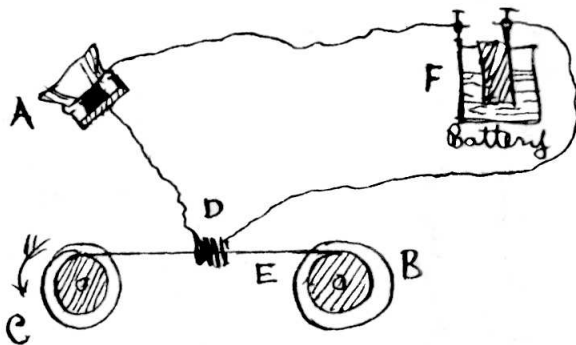

While talking into A, the varying intensity of current (caused by the varying condensation of the carbon) produces zones, or spots, of magnetism in E which vary in length and strength in accordance with the length and amplitude of the sound vibrations. The wire becomes the record of the voice, instead of tinfoil.

The "talker" consists of the same reels; the same or another helix, battery &c.; a Hughes microphone and a Bell telephone. The magnetic wire, E, being passed through the helix, induces a delicate series of currents of magneto-electricity which pass through the microphone

and are given out as sound vibrations by the telephone: or otherwise.

The advantages in cheapness, simplicity and delicacy, are manifest --- also the facility with which the record may be kept wound on cheap spools, like sewing cotton.

Oberlin Smith.

If wire E will not magnetize in "spots", it could be a chain of alternate links of steels & non-magnetizable material.

Sep. 24,

F.F. Smith & I have just jointly suggested a wire, E, made of brass, lead or other metal, impregnated mechanically with steel dust --- probably hardened in the wire.

O. Smith.

This was described to me Sept. 24th, 1878.

P. K. Reeves.

Certification of SAMUEL M. SHELDON

*Certification of SAMUEL M. SHELDON, County Clerk of the
County of Cumberland, December 23rd, 1908*

STATE OF NEW JERSEY)
COUNTY OF CUMBERLAND) SS.

I, SAMUEL M. SHELDON, County Clerk of the County of Cumberland aforesaid, do certify the foregoing to be true copies of the Memorandums therein recited, the originals thereof having been found in my office in an envelope bearing the printed endorsement of The Ferracute Machine Co. and the following written endorsements "Memoranda of Improvements in Phonographs by Oberlin Smith Sept. 24th., 1878" and "Filed Sep. 24, 1878, Daniel Sharp, Clerk."

And I further certify that at the last mentioned date Daniel Sharp was County Clerk of said County.

IN WITNESS WHEREOF, I have hereunto set my hand and affixed the seal of said County, this 23rd. day of December, A.D., 1908.

(Seal) [written] Samuel M. Sheldon
County Clerk.

This is to certify that on the twenty-fourth day of September, 1878, I was in the employ of the Ferracute Machine Company, a corporation of New Jersey, located in Bridgeton, Cumberland County of said state, at

which time the president of said company was Oberlin Smith and the secretary and treasurer was Fred F. Smith, and while in said employ I assisted Oberlin Smith in sundry experiments relating to the production of phonograph records. I further certify that I have examined the document filed by him on said date in the office of Clerk of Cumberland County, New Jersey and that my name as it appears appended thereto is my signature made on or before said date.

10 Bridgeton, N.J., December 24th, 1908

Witness: [written] Henry A. Janvier
P. Kennedy Reeves.

15 **Letter of the Department of the United States Patent Office**

Letter of the Department of the United States Patent Office, Washington, D.C., to O. Smith of about January 1901

Assignment Division.

20 All communications should be addressed to
"The Commissioner of Patents,
Washington, D. C."

DEPARTMENT OF THE INTERIOR
UNITED STATES PATENT OFFICE,

25 Washington, D.C., 18

Sir:

Your letter of Jan. 29/01 (No. 17006) has been received. In reply you are informed that a copy of the Caveat filed Oct. 4/78 by Oberlin Smith for Electric Phonograph or Recording Telephones will be prepared and forwarded to your address on receipt of \$ 1.85

RETURN THIS CIRCULAR WITH FEE.

Very respectfully,

Mas. copy 1.60
Blue print .25

35 [signed] C. H. Duell
Commissioner of Patents.
Mr. Oberlin Smith
Bridgeton
N.J.

40 *The Caveat of October 4, 1878. 9 pages including 3 figures. Preserved as an official copy of the original document. Drawings are CAD reproductions.*

CAVEAT.

To the Commissioner of Patents:

45 THE PETITION OF Oberlin Smith, of Bridgeton in the County of Cumberland, and State of New Jersey, Respectfully Represents, That he has made certain improvements in Electric Phonograph or Recording Telephones and that he is now engaged in making experiments for the purpose of perfecting the same, preparatory to his applying for Letters Patent therefore. He therefore prays that the subjoined description of his invention may be filed as a Caveat in the Confidential Archives of the Patent Office, agreeably to the provisions of the act of Congress in that case made and provided: He having paid Ten Dollars into the Treasury of the United States, and otherwise complied with the requirements of the said act.

Oberlin Smith.

60

TO ALL WHOM IT MAY CONCERN:

BE IT KNOWN, That I, Oberlin Smith, of Bridgeton in the County of Cumberland, and State of New Jersey have invented certain new and useful improvements in Electric Phonographs or Recording Telephones; and do hereby declare that the following is a full, clear, and exact description thereof reference being had to the accompanying drawings making a part of this specification in which

Fig. 1

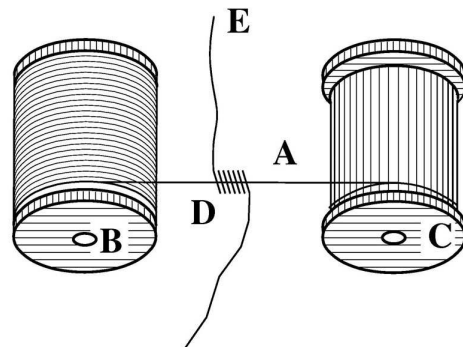

70 Figure 1 is a perspective view of my improved mechanism for recording or storing the messages transmitted by a telephone;

Figure 2 is a like view of the entire apparatus when arranged solely for recording;

Figure 3 is a perspective view of said apparatus arranged both as a transmitter and receiver, and with recording mechanism at each end of the line.

Letters of like name and kind refer to like parts in each of the figures.

The design of my invention is to enable messages transmitted by telephone to be recorded and repeated phonographically any desired number of times without wear or injury to the recording mechanism and with greater accuracy and delicacy than has heretofore been practicable, to which end

It consists, in a recording mechanism for use with telephones composed of the following elements; viz; First, - a cord, ribbon or other equivalent flexible filament constructed from non-magnetic material, and provided at suitable intervals with pieces of insulated metal which, by the action of electricity are capable of becoming permanent magnets; Second, - helical mechanism or other electro-magnetic producing apparatus upon a telephonic line wire by means of which any one of said insulated pieces of metal may be magnetized when brought to or near the same, and Third, - means whereby said cord, ribbon, etc., may be caused to move longitudinally so as to bring its surface against or near the said helical mechanism, substantially as and for the purpose hereinafter specified.

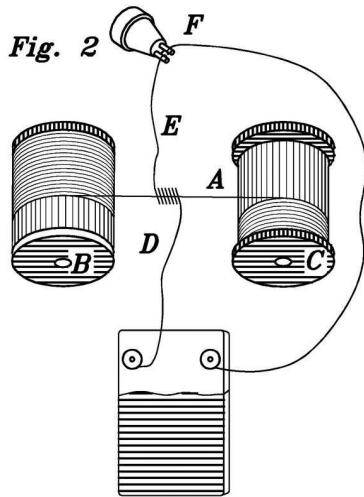

In the use of my invention, I employ a cord, ribbon, or other equivalent flexible filament A which is constructed from cotton, silk brass or other non-magnetic material, and at suitable intervals along its entire length contains pieces of hardened steel that are securely held in place and prevented from independent motion and are insulated from the other. The said piece of steel may be in the form of filings and may be embedded into the surface of said cord by pressure or other suitable means, or they may - as when metal alone is used - form regular

sections or links of the filament or chain, the result being the same in each instance.

Fig. 3

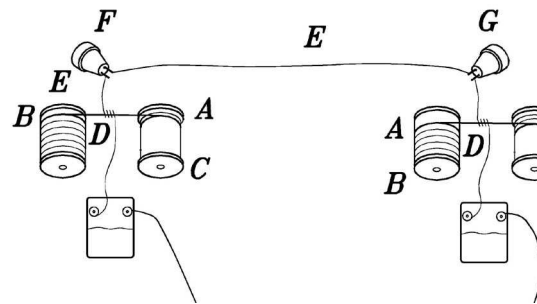

The filament A is caused to move longitudinally by being wound from one spool B upon a second spool C, or by any equivalent means, and passes through a helix D which is provided at a suitable point upon a telephonic line wire E. When the telephones F and G are in use, the current of electricity passes through the wire E in a series of waves which vary in length and intensity and each electric wave in passing through the helix D causes the pieces of hardened steel which are then passing with the filament A through said helix, to become permanently magnetized, the degree of such magnetism being governed by the amplitudes of the electric waves producing the same, while the length of each wave will determine the number of pieces of metal magnetized.

It is intended that the recording filament shall be set in motion before the telephone is used and its motion arrested when said telephone is no longer required, as in case of printing telegraph machines, which movements may be governed by currents of electricity from either end of the line.

By placing the recording mechanism at each end of the line, the transmitter as well as the receiver can have a record of each message sent and, thereby, be enabled to know with certainty the message sent to him.

When it is desired to repeat a recorded message, the filament A is rewound upon its spool or container B and then passed through the helix D (which is disconnected with a speaking telephone) with the same velocity and in the same direction as before, when it will be found that each of the small-permanent magnets in said helix and, through the latter cause vibrations corresponding to the length and intensity of the original currents.

Should the induced currents of magneto-electricity be too weak, any desired intensifying apparatus, as for instance, a battery with some modification of a Hughes Microphone, may be placed in the line.

Should the contact of the magnetized portions of steel within the filament A, as the same is wound upon its spools, prove injurious, such contact may be avoided

by winding with said filament a tape constructed from cotton, or any suitable substance which is non-magnetic.

In the case that the magnetic action of the helix is not sufficiently limited to enable the electric wave to be defined with accuracy, the filament A may be caused to pass near to, but not through said helix with its surface in contact with a soft metal bar which is contained within said helix, the result being that the electric current will be caused to operate upon said filament only at such point of contact and its operation may thus be accurately defined and limited.

Having thus set forth the nature and merits of my invention, what I claim as new, is ---

A recording mechanism for use with telephones, composed of the following elements; namely, viz:

First, a cord, ribbon or other equivalent flexible filament constructed from non-magnetic material, and provided at suitable intervals with pieces of insulated metal, which, by the action of electricity are capable of becoming permanent magnets; Second, helical mechanism or other electro-magnetic inducing apparatus upon a telephonic line wire by means of which any one of said insulated pieces of metal may be magnetized when brought to or near the same, and Third, means whereby said cord, ribbon, etc., may be caused to move longitudinally so as to bring its surface against or near to said helical mechanism, substantially as and for the purpose described.

In Testimony That I claim the foregoing I have herunto set my hand and seal this 1st day of October 1878.

Witnesses:

Fred L. Smith

Oberlin Smith.

P. Kennedy Reeves.

The Electrical World, September 8, 1888, pp. 116 f. Italics as in original.

Some Possible Forms of Phonograph.

BY OBERLIN SMITH.

There being nowadays throughout the scientific world great activity of thought regarding listening and talking machines, the reader of THE ELECTRICAL WORLD may be interested in a description of two or three possible methods of making phonograph which the writer contrived some years ago, but which were

laid aside and never brought to completion on account of a press of other work.

One of these methods is rudely shown in Figs. 1, 2 and 3, the construction and operation being as follows: A is a mouth piece and diaphragm, with spring and indenting needle, as in the Edison machine. B is a reel, carrying a thin ribbon E of iron, steel or other substance capable of being temporarily softened by heat. This ribbon is unwound from B and wound on to another reel C, which is revolved slowly by clock work or other means. D is a supporting roller (or stationary bar) with a flat groove the width of the ribbon E, and having a V-groove in the bottom of it for the needle descending into, as seen in Fig. 2. F is a heating lamp, which, of course, must be protected from draughts, etc. All this is the recording apparatus or transmitter. The ribbon E being short <soft> at the point where, for the time being, it is hot, receives the indentations as easily as the tin-foil, or more so. It cools by the time it gets to reel C, and is then much harder and more durable than tin foil. The same apparatus can be used for the "talker", as in Edison's machine, but advantage may be taken of having the indented ribbon made of hard substance by using a special talking diaphragm G, Fig. 3, which will augment the vibrations in amplitude by means of a lever H, the ribbon E being hard enough not to lose its form by the increased pressure due to the leverage, as thin-foil would do.

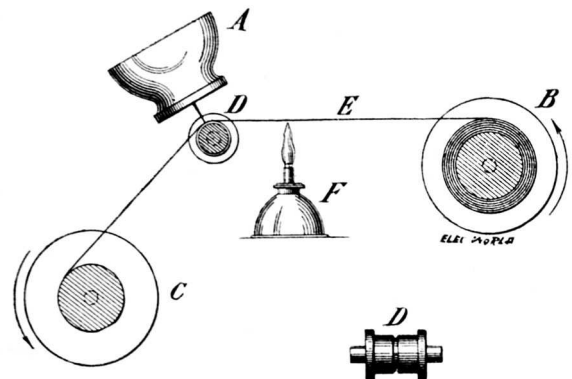

FIGS. 1 AND 2.—SOME POSSIBLE FORMS OF PHONOGRAPH.

The probable advantages of this form of apparatus are: 1. The loudness of voice produced by the increased amplitude of vibration. 2. The simplicity and cheapness of the whole machine - requiring no accuracy in "registering" devices beyond having the groove in roller D to about fit the width of ribbon E. 3. The cheap material of which the ribbon may be made. 4. Durability of ribbon, even with oft-repeated use. 5. Convenience and freedom from injury in handling and transporting the ribbon-record when wound upon spools like thread. This ribbon would, if of iron or steel, probably be about 1/20 inch wide and 1/200 inch thick.

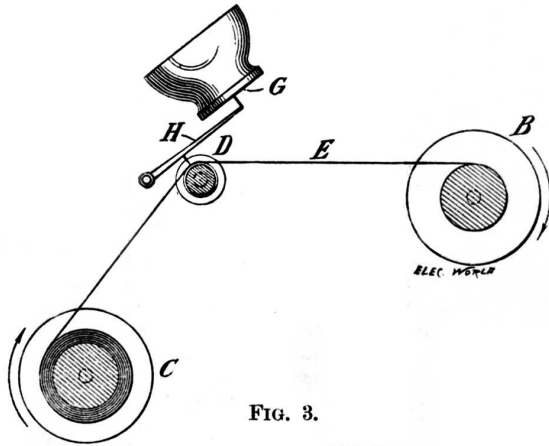

FIG. 3.

Its disadvantages, possibly fatal ones, would be the difficulty of evenly heating the metal ribbon and the probable rasping noise which would occur in the diaphragm when the sound was reproduced. A modified and somewhat simpler form of the above process might be employed by using an ordinary wire instead of the ribbon E, and allowing a chisel-shaped needle to indent it into a flattened and somewhat widened form, wherever it was struck.

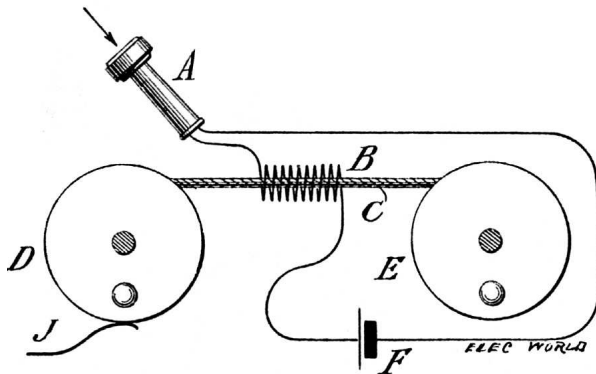

FIG. 4.

The above two methods are, of course, wholly mechanical, as in the ordinary phonograph. The following proposed apparatus is, however, *purely electrical*, and is, as far as known to the writer, the only one fulfilling such conditions that has been suggested. Fig. 4 is the recording part of an electrical phonograph. Fig. 5 is the talking part of the same. Many of the pieces, as D, E, B, C, etc. can be the same ones as are used in Fig. 4. Fig. 6 shows the same ideas applied to a telephone line wire, so as to speak at a distance and at the same time record what is said, thus making a *recording telephone*. The sketches show only the essential parts, without the supporting framework, etc.

In Fig. 4 the voice or other sound is delivered into an ordinary telephone A. Preferably, this should be a carbon transmitter so as to have battery F in the circuit, and thus use as strong a current as practicable. Possibly,

however, a Bell telephone without a battery would answer the purpose. In either case the current, broken into waves of varying lengths and intensities corresponding with the vibrations of the diaphragm in the telephone, passes in its circuit through the helix B, converting into a permanent magnet any piece of hardened steel which may be at the time within the helix. Through this helix B passes a cord, string, thread, ribbon, chain or wire C, made wholly or partly of hardened steel, and kept in motion by being wound on to the reel E from off the reel D, E being revolved by hand, clock-work or other means. J is a tension spring or brake pressing against D to keep the cord C taut.

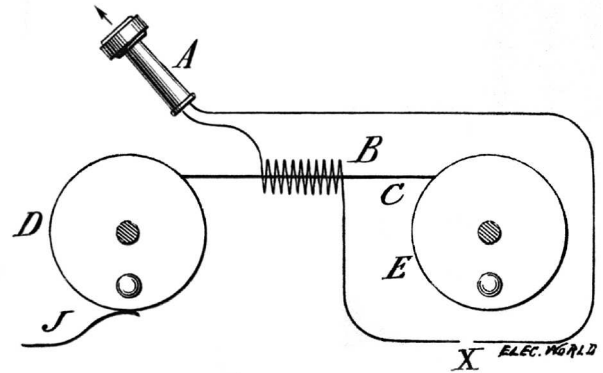

FIG. 5.

When in operation with the undulatory current from the telephone A passing through the helix, the cord C becomes, so to speak, a series of short magnets grouped into alternate swellings and attenuations of magnetism. The actual lengths of these groups depends upon the speed of their motion, but their *relative lengths* depend upon the *relative lengths* of the sound wave; and their *relative intensities* depend upon the *relative amplitudes* of these waves. The cord C therefore contains a perfect record of the sound, far more delicate than the indentations in the tin-foil of mechanical phonograph. The probable construction of C would be a cotton, silk or other thread, among whose fibres would be spun (or otherwise mixed) hard steel dust, or short clippings of very fine steel wire, hardened. Each piece would, of course, become a complete magnet. Other forms of C might be a brass, lead or other wire or ribbon through which the steel dust was mixed in melting - being hardened afterwards in the case of brass or any metal with a high melting point. Another (but too expensive) form of C would be a chain with each link a magnet; or, if the magnets affected each other too much when in contact, each alternate link could be of non-magnetic material. This chain would not be as delicate as the dust magnets, because the effects of a given vibration might extend but part way along a link. Another imaginable form of C would be simply a hard steel wire, but it is scarcely possible that it would divide itself up properly into a

number of short magnets. The magnetic influence would probably be distributed along the wire in a most totally depraved way, with nodal point just where they were not wanted. If it could be made to work it would obviously be the simplest thing yet suggested.

The cotton thread above mentioned would seem to be preferable to anything else on account of its cheapness, lightness and flexibility. The Lord's Prayer could be written upon a few feet of thread or string, while a young lady receiving a small spool of cotton from her lover would think herself abominably neglected if it was not "warranted 200 yards long".

In Fig. 6 the arrangement is precisely the same as in Fig. 4, except that the circuit is made through the telegraph wire W and the receiving telephone H in Boston or some other distant place. Of course the record might be made at the receiving instead of the transmitting end of the line, and thus our hypothetical young lady might, while listening to the impassioned pleadings of her chosen young man, be preparing the evidence for a future breach-of-promise suit.

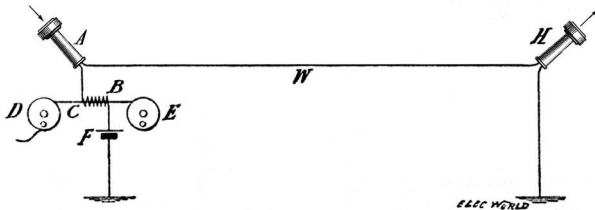

FIG. 6.

To make the thread or cord C "talk back" it is, after having been rewound on the reel D again drawn through a helix B, Fig. 5, in whose circuit is the "talking" telephone A, probably a Bell receiver. Of course it is drawn through at approximately the same speed as before. In passing, the small permanent magnet in the cord C induce currents of electricity in their enveloping helix analogous to the currents in the fields of a magneto-electric machine, or a dynamo with permanent magnets in its armature. A more exact analogy would, however, be the currents in the helix of a solenoid if its ordinary action were reversed, and its core made a permanent magnet. These waves of current will correspond in length and relative intensity with the original wave currents, and will therefore reproduce the vibrations of the original sound in the diaphragm of the telephone at any time in the future. If such induced currents are not strong enough to produce sufficiently loud sounds it may be possible to insert at X, Fig. 5, some intensifying apparatus, such as a battery, but which has not yet been thought out.

Like the two mechanical methods first mentioned, this electrical method has never been worked out to

completion. The writer went far enough with it to build a temporary apparatus and to develop a successful machine for spinning metallic dust into a cotton cord, but was obliged to lay aside the whole thing before arriving at any *acoustic* results. His experiments showed that it was difficult, with ordinary tools, to harden steel filings on account of excessive oxidation. Experiments with hardened steel wire, broken in a special machine into very short pieces, showed that they must not be too short - say not less than three or four times their diameter - or they could not be saturated with magnetism to any appreciable degree. Possibly this is because the poles (or points of maximum polarity) of a magnet lie at some distance from the ends of the bar, and consequently neutralize each other when the bar is too short. If this theory is correct it would prevent making magnets of steel dust, the grains of which are supposed to be about as broad as they are long.

To digress a little, it may be remarked that such a theory does not seem to agree with the fact of magnetic polarity in approximately spherical or cubical bodies, like the earth, or a chunk of loadstone. Possibly, however, they would be much stronger magnets if elongated; and the tiny pieces of wire above referred to, may possess as much strength in proportion, though it be scarcely perceptible on account of their smallness.

The writer confesses to a good deal of ignorance upon the subject, but he was somewhat surprised to find an equal amount in several well known electricians whom he consulted; and also to find that none of the books he had at hand gave any definite data regarding the best proportions for permanent magnets or their actual strength (when saturated) in pulling power. Surely, there is in this department of electrical science a good sized (magnetic) field for a number of lines of force - mental ones - to work in, in the way of careful experimenting.

To return to our magnetized cord as a "phonogram", it is possible that an insuperable objection to it would be found in the great diameter and length which would be required to hold magnets of sufficient strength and quantity. This, however, can be determined by experiment only. Of course if this cord approached a clothes line rather than a piece of sewing silk, in its general proportions it would be utterly useless as a practical recording medium. Regarding the general convenience of a record in a cord or ribbon-like form compared with one indented upon a cylinder or a flat circular tablet, there are probably advantages on both sides. One disadvantage of the cord is that if some small portion of the record near the middle has to be repeated there is a good deal of unwinding to do to get at it. The same objection, if it be one, applies to the first-mentioned methods, as well as the magnetic cord. In practice, however, it might

prove that this unwinding was a small matter, if a rapidly working automatic winder were used.

Another general principle which may perhaps be adopted for a phonograph is that of *variable conductivity*. Possibly a cord or ribbon may be made of a poor conductor (perhaps a flexible substance impregnated with carbon), and may then be made better and worse in certain spots by the action of the "transmitting" instrument, either by making spots of the cord denser or thinner, in some way, at the inward stroke of the diaphragm. This recording action would probably be entirely mechanical. The reproducing, on the contrary, would be wholly electrical, and would consist of passing a current through a conductor which was broken by a space filled by the cross-section of the moving record. This current would pass through a receiving telephone and would, obviously, be thrown into the proper undulations of strength by the varying conductivity of the cord, as it passed along by the motion of its reels.

The writer has not worked out the details of this latter scheme as completely as in the other mentioned - even upon paper. He has not the time, to say nothing of a properly equipped laboratory, to carry the ideas suggested to their logical conclusion of success or failure, and, therefore, makes them public, hoping that some of the numerous experimenters now working in this field may find in them a germ of good from which something useful may grow. Should this be the case, he will doubtless get due credit for his share in the matter; but if, on the other hand, these suggestions prove worthless, they will still have served a purpose, on the principle that a demonstration of what *can't* be done is often a pertinent hint to what *can* be.

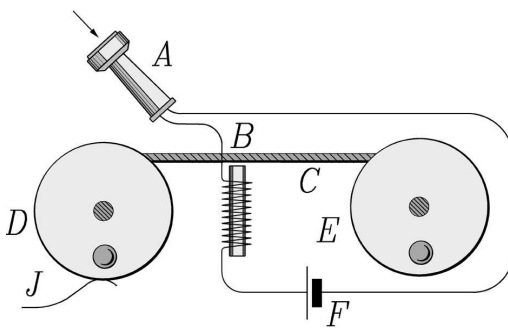

35 *The Electrical World, Sept. 29, 1888, p. 179*

MISCELLANEOUS NOTES.

Possible Phonographs*. - With regard to his recent article Mr. Oberlin Smith writes: "In my article upon 'Possible Phonographs' in your issue of Sept. 8 in the second paragraph, fourteenth line, the word 'short' should read 'soft'. In the cuts, Fig. 4 and 5, the helix should be shown very short, and possibly might consist

of only one coil, as with the long helix represented it would be impossible to localize the magnetism in the way desired. These cuts, of course, are conventional, and are merely intended to show the principle involved. At the time I experimented I also tried drawing the cord across the corner** of an electro-magnet around which the helix was wound, instead of allowing it to act directly upon the cord. This would probably be a better way, providing there was not too much magnetic inertia to prevent rapid action. This I feared at the time, but on further reflection it seemed as if such a magnet ought to work as quickly as the magnet of the telephone itself."

55 * refers to a Letter to the Editor by R. M. Hunter, *The Electrical World*, Sept. 22, 1888, titled "Impossible Forms of Phonograph".

** "corner" is presumably a typo for "core".

60 The Correspondence to T. A. Edison

OBERLIN SMITH, President
FRED F. SMITH, Sec. and Treas.
OFFICE OF THE FERRACUTE MACHINE CO.
Foot and Power Presses, Dies, and all other fruit Can Tools:
65 Special Hardware Drilling Machines: Pipestocks and Dies.

Bridgeton, N. Jersey, Nov. 26, 1878.

Mr. T. A. Edison

70 Dear Sir:-

In some amateur electrical experiments I am making, I need a "button" of mercury-impregnated carbon, similar to those you use in your carbon telephone. Can you kindly furnish me one? If so, please state what will be the price, that I may remit.

How come along the specifications for the new pattern of phonograph about which our Co. corresponded with you a few months ago?

Yours very truly,
80 Oberlin Smith.

(FERRACUTE letterhead as above)

Bridgeton, N. Jersey, Dec. 6, 1878.

85 Mr. T. A. Edison, Menlo Park, N.J.

Dear Sir:-

Yours of Nov. 29 is recd. to our Mr. O. Smith. We wrote to Mr. Scott and have had a permit from him which we enclose.

90 Please mail us a carbon button (mercurialized as you use them in the telephone) or, if not expensive, two of them. They are to be used only in amateur laboratory experiments. Mail bill and we will remit.

With thanks for your kind attention we are yours truly
Ferracute Machine Co.
Per O. Smith, Pres.

5 OBERLIN SMITH, FRED F. SMITH,
President OFFICE OF THE Sec. and Treas.
FERRACUTE MACHINE CO.
Foot and Power Presses, Dies, and all other fruit Can
Tools:
10 Special Hardware Drilling Machines: Pipestocks and Dies.

Bridgeton, N. Jersey, Dec. 13, 1878.

Mr. T. A. Edison
Menlo Park, N.J.

15 Dear Sir:-

The buttons have just arrived. Thanks for your kind
attention. We enclose \$2. in payment.

To get the heat effects in a greatly variable resis-
tance, do you use a single button (compressed of course
20 between 2 gelatinum covered plates) or several piled
together? If the latter method, how many? The reason
we ask is that the buttons are thinner than we supposed.

Yours very truly,

Ferracute Mach. Co.,
25 Per O. Smith, Presd.

*A letter from T. A. Edison to Oberlin Smith, dated May, 9,
1882:*

9th May

30 Ferracute Machine Co
Bridgeton

New Jersey

Referring to your favor (?) of 5th I beg to state that I
sold my telephone interests to the American Speaking
35 Co., who have an arrangement with the American Bell
Telephone Co. of Boston, Mass., by which the latter has
control of my telephonic inventions.

Yours sincerely
Thos A Edison

40 **"Smith versus Poulsen"**

*Excerpts of the correspondence between the United States
Patent Office and W.A. Rosenbaum, Patent Attorney of
Valdemar Poulsen. Original correspondence (approx. 80
pages) made available by James W. Gandy in 1989.*

45 DEPARTMENT OF THE INTERIOR,
UNITED STATES PATENT OFFICE

Washington, D.C., June 28, 1900.

Valdemar Poulsen,
Care, W.A. Rosenbaum,
50 Times Building,
New York, N.Y.

Please find below a communication from the EX-
AMINER in charge of your application filed July 78,
1899, Ser. No. 723,198, for Method of and Apparatus
55 for the Storing up of Speech or Signals by Magnetically
Influencing Magnetisable Bodies.

C.H. Duell, Commissioner of Patents.

This application has been examined as amended.

The new drawings are still objectionable to the same
60 extent as the old ones. Figure 6 of the new drawings
covers new matter not originally disclosed and must be
cancelled. The small figure to the right of figure 3 must
be properly identified.

The descriptive matter at the bottom of page 2 and
65 top of page 3, relating to figure 6, is new matter and
must be cancelled. It is not seen how the double pole
electro-magnet acting simultaneously on adjacent wires
will operate, as it is presumed that each pole traverses
the entire length of wire and said pole must necessarily
70 traverse the path previously passed over by its compan-
ion pole. After the first convolution is passed both poles
engage portions of contiguous wires and a great confu-
sion of sound would result. It would appear that appli-
cant's device would operate only with a single pole in
75 contact with a single convolution of the wire.

Stud 44 is not shown. The clock work must be
clearly indicated in its relation with the other mecha-
nism.

The substance of the first complete paragraph of
80 page 11 embraces new matter. Said paragraph must be
cancelled.

The method claims embraced in this case in so far as
they distinguish from the apparatus are fully anticipated
in the article "Some possible forms of Phonograph" by
85 Oberlin Smith, published in the Electrical World, Vol.
12, Sep. 8, 1888, page 116, and are rejected.

[Signature]
Examiner, Div. 16

New York, July 11, 1900.

In re application of
V. Poulsen,
Method of Electromagnetically Storing up
Speech or Signals,
Filed July 8, 1899, Serial #723,198

Hon. Commissioner of Patents:-

(...) A careful examination of the article by Oberlin
Smith, published in the Electrical World, has been
made, and it does not appear that this disclosure is a
valid anticipation of applicant's invention. The author
expressly states that he did not perfect the invention and
did not obtain any results whatever. He has not given
the public the benefit of his invention, since the way to
carry out his idea in a practical manner is not disclosed.

It is submitted that since applicant has independently
evolved the idea and reduced it to practice, he is entitled
to a patent covering the broad method, notwithstanding
anything disclosed in the Smith article.

Respectfully,
W.A. Rosenbaum
Atty.

*Letter No. 569, transcribed from a business letter note
book, from Oberlin Smith to Chas. A. Lieb, probably a
patent attorney, in New York, N.Y.*

November 5, (1900)

Mr. Chas. A. Lieb,
20 Broad St., New York.

Dear Sir:-

The date of the article in the "Electrical World" de-
scribing my phonograph, was September 8, 1888.

I find I have but one copy or would send it to you. If
you have not ready access to a file of the "World" I will
send you my copy and have it returned, in case you
want to look it over.

As I stated to you verbally, I, being, the original in-
ventor of this phonograph in its essential principles, and
having given much (illegible word) thought to the mat-
ter, should be glad to have a finger in the pie of its fu-
ture development. It may be that I can be of use in
(three illegible words) improvements which no doubt
are needed before it is put in practical shape.

As a separate matter, it may be (that) I can have a
hand in manufacturing some forms of the machine when
it has been developed in proper shape to put upon the
market. This development should be done in part at least
by whoever is going to manufacture them, that there

may be entire harmony in the design and the tools and
methods by which it can be cheaply manufactured in
duplicate.

I mail you our "Catalogue 14", showing some of the
presses etc. which our Company manufactures. From
the prices listed therein we give a discount of 10%.

I enclose an old catalogue of the American Society
of Mechanical Engineers, of which I have long been a
member, and am a past President. It is probable that you
know many of the members, about whom we can com-
pare notes when we meet.

Yours very truly,

Catalogues
Enclosures

P.S. In my caveat (of earlier date) I propose an elec-
tro-magnet, if proved desirable, for the helix to surround
instead of being around the wire of record. This is as
you have it.

70

*Letter No. 534, transcribed from a business letter note
book, from Oberlin Smith to The U.S. Commissioner of
Patents, Washington, D.C.*

November 9, (1900)

The U.S. Commissioner of Patents,
Washington, D.C.

Gentlemen:-

I enclose clipping from the New York Herald in re-
gard to an alleged new phonograph which takes its re-
cords upon a piede co wire, magnetized with different
intensities at different spots- all of which will explain
itself. I write to call your attention to the fact that I in-
vented this system, and filed a caveat for it in your of-
fice a good many yeras ago, and some years afterwards
I wrote and published a full description in one of the
most prominent electrical journals in New York- the
Electrical World.

If there has been any recent patent issued for this
scheme will you kindly let me know the number and
date, that I may order a copy.

Yours very truly,

enclosure

From a scrapbook of Smith's inventions, typewritten paper, dated 3/20, 1908

1878 9/24 Deposited at County Clerk's Office Sept. 24
Improvement in Phonographs About April 30
5 Sept. 24 Improvement in Phonographs - Electrical

I have conceived of the idea of an attachment to an ordinary Columbia or Edison phonograph for automatically removing one cylinder and putting in others in succession, to the extent of a dozen or so, so as to play a series of tunes continuously without attention.

This in the main consists of a turret with its axis parallel to the axis of the main drum of the phonograph but some distance above or to one side of the same, projected. This turret carries several studs parallel to its axis, each one of them coming into line with the phonograph drum when revolved to the proper indexed position.

A proper cam mechanism revolves the studs to the successive positions required then pushes a cylinder which is strung loosely on a stud on to the drum, with a spring pressure to give proper tightness, then starts the phonograph needle-feeding mechanism and allows the tune to play, and after this it removes the cylinder back onto its studs and, moving around another one, puts it so it gets busy, and so forth.

The Letter to the Franklin Institute. Typewritten paper, 15 pages, dated October, 1911

CORRESPONDENCE.

THE TELEGRAPHONE (AN HISTORICAL NOTE.)

To the Journal of the Franklin Institute:-

In response to a request from one of the members of your Science and Arts Committee for a statement of my work in connection with the inception and subsequent development of the Telegraphone, I have collated the following data on the subject:

As is well known, this device is a form of phonograph which is capable of recording sounds and of reproducing them over and over again, being in this respect similar to the various well-known cylinder and disk machines in common use under the names of Phonograph, Graphophone, Gramophone, etc. These latter are all purely mechanical in their operation, the general principle embodied being that of a cam in the form of a spiral groove on the face of a cylinder or disk, originally wax or soap-like material, and which is reproduced in a harder substance in various ways. The cam-groove is produced by ploughing into the surface with a stylus

forming a fine cutting tool, which is operated by a diaphragm vibrated by the impact of sound waves, the incised groove having either on the bottom or the sites minute sinuosities corresponding with the pitch and amplitude of the sound waves. The reproduction of these waves is effected by the vibration of a reproducing diaphragm, provided with a stylus held in the groove of the record disk or cylinder, and actuated by the corrugations of the groove as the cylinder or disk is revolved. The reproduced sound shows a loss of both force and delicacy as compared with those which produced the record, owing to the blunting or restriction of the original sound waves by the resistance of the work which they perform in generating the cam groove of the record.

In the production of the original sound waves in this manner, certain others of an undesirable nature are formed in consequence of the scraping of the needle against the cam groove, which results in adulterating the normal waves. Hence, the disturbing undertone of scratching, which, more or less pronounced, is always present in the otherwise admirable renditions produced by an instrument which, in spite of all its imperfections, is one of the most simple and remarkable of all modern inventions. This seems more wonderful when we consider that not only primary waves representing pitch and power are recorded but also the secondary waves, as we may call them, which pertain to the overtones, and which determine quality and articulation.

As already indicated, the cylinder phonographs and some of the disk machines depend upon the sinuosities representing the sound waves being formed on the bottom of the cam groove instead of on its sides, thus moving the needle in and out in a direction at right angles to the general surface. In other disk machines, those of the gramophone type, the groove is of uniform depth, its horizontal sinuosities causing the needle to move side-wise in a direction parallel to the disk surface.

In an early acquaintance with Mr. Edison he showed me his recently invented phonograph machine in which a cylinder coated with tinfoil both received and reproduced the remarks made to it. This he jokingly informed me would run backward and would reproduce the words "mad dog" into something that sounded more profane, if not so dangerous. I presently acquired one of these phonographs and soon after coming to use it I was led to consider the possibility of producing the phonographic effects electrically, being greatly impressed with the necessity of avoiding the scraping and grinding noise incident to reproducing the sound mechanically. It occurred to me that a really good talking machine must be one having as pure a tone as a receiving telephone, and my efforts in this direction resulted in my contriving an apparatus which took almost exactly the same form as

the modern "wire-record" machine, known as the Tele-
graphone. The first crude description and sketch of the
device which I then prepared were placed in a sealed
envelope which was deposited and filed (as a matter of
future evidence) in the Clerk's Office of Cumberland
County, at Bridgeton, New Jersey. This document is
dated Sept. 23, 1878, and is attested on the record as of
Oct. 1st, 1878. It reads as follows:

(follows "Second Memorandum", see page 13)

A few days later, under the date of Oct. 4, 1878, I
filed a caveat in the U. S. Patent Office which reads as
follows:

(follows "The Caveat", see page 14)

In the "Memorandum" filed at Bridgeton, and re-
ferred to above, there is an omission of an important
feature included in the modern working instrument,
namely, the running of the record wire over the com-
paratively sharp edge of an electro-magnet rather than
through a helix as shown in the sketch appended to the
memorandum. This was, however, rectified in the Ca-
veat, where, in the sixteenth paragraph, is specified an
alternative of so running the wire in case the effect with
the helix should not be as delicate as would be desir-
able. Theoretically, however, a helix would doubtless
answer the purpose, providing the wire travelled fast
enough to reduce the effect of unnecessary elongation of
the record and the correspondingly long spots of mag-
netism. The interventions of a sharp corner shortens the
spots and makes the record much more compact.

It will be noticed that in the Caveat there is no men-
tion of a hardened-steel wire to form the record. The
description is limited to certain more complicated meth-
ods of obtaining the desired effect by inserting pieces of
hardened steel into some other kind of a wire, chain or
filament. This omission, the writer recollects, was acci-
dental, he having verbally mentioned the wire, as an
alternative, to his Patent Attorney. It had earlier oc-
curred to him to make use of a wire as the simplest and most
obvious means to the end in view, providing it would
work well enough in practice. This is indicated in the
"Memorandum" of Sept. 23rd, where it speaks of "the
moving wire E through helix D", in which "the varying
intensity of current" produces zones or spots of mag-
netism which vary in length and strength in accor-
dance with the length and amplitude of the sound vibra-
tions". Thus the two documents together cover com-
pletely the general principles involved in the Telegra-
phone.

It should be noted that in the eighth and ninth para-
graphs of the Caveat, the word "insulated" obviously
refers to magnetic and not to electrical insulation,
though it should perhaps be so stated. At the time the

telephones procurable were rather imperfect, and I en-
countered a good deal of trouble in arranging a battery
current to work with them properly. Before I got the
apparatus into practical shape my attention had to be
given to important current affairs, and I was unable to
resume my experiments thereafter. Such models as I had
were placed in a store-room of our works and remained
there until a fire a few years ago entirely destroyed the
buildings and its contents.

Ten years after the interruption of my work I con-
cluded to give up my project to the Public and accord-
ingly published in the New York Electrical World of
Sept. 8, 1888, a full description of my invention with an
invitation for it to be developed and perfected by later
workers.

The only doubt which yet needed to be resolved by
experiments was whether the invention could be com-
mercially wrought out without too great bulk and com-
plication. We all know that magnetism may be localized
in a magnetic body in spots of more or less intensity, as
witness the poles in a bar magnet, and the magnetic
poles of the earth. It is also obvious that a very long
slim wire could contain such spots at some distance
apart which, if passed along quickly enough would
affect the intensity of the current in a receiving tele-
phone and would cause its diaphragm to vibrate. The
only question to be later determined was, whether the
spots could be placed closely enough in the wire with-
out interfering with each other, to make a record for
practical use.

The assumption, therefore, in my original "Memo-
randum" was based on the well-known principles of
physics, much as if it had been some peculiar kind of
pump embodying a pipe in which a liquid and a gas
could flow in alternate spots (as they do in the syphon
pipe or a steam gauge) without mixing together, except
at the edges of the spots. Such an intervention would be
valid and would be certain to work, providing its dimen-
sions were suited to its working conditions. Its princi-
ples may be patentable and yet experiment might prove
it to require so long a pipe as to make it commercially
impracticable. In just such a condition was the telegra-
phone when I gave it to the Public for further develop-
ment.

Several years later such a development was accom-
plished by Mr. Valdemar Poulsen of Denmark, who
made, and exhibited at the Paris exposition of 1900, a
beautiful machine which actually talked from a reel of
wire - its construction being precisely according to the
principles outlined in the original documents.

Since his completion of the wire-record machine,
Mr. Poulsen has made the curious discovery that spots
of permanent magnetism may not only be made in a

piece of wire (where, of course, they may be strung along at a considerable distance apart) but that they may be created on, or near, the surface of a sheet of hardened steel and may lie in lines parallel with each other and rather close together. Thus, in one of his ingenious machines, provided with a revolving steel cylinder, he has "talked" a spiral line of magnetic spots from the point of a needle-like electro-magnet, controlled as usual by a telephone, which will afterwards "talk back", so to speak, when again revolved with this magnet in the circuit of the receiving telephone. Later, he has gone even further than this and has produced a disk machine where the lines of magnetism are in a flat spiral upon a cheaply stamped-out sheet-steel disk. Further still, he has discovered that both sides of the disk can be used, each for a separate record. Obviously, the devices for operating this disk would somewhat resemble those employed in the usual machine of this type. There must, of course, be a feeding mechanism to make the point of the magnet travel exactly over the line of spots already generated, in the same way as with any other machine making the same form of spiral. Great accuracy however, is required to exactly hit the invisible spots when reproducing.

Such a machine, if made large enough to contain a sufficient record, would be preferable to the wire-record type. It would be simpler in construction and would not have to be run backward to get ready to start again. So far, however, no means have been devised that will sufficiently amplify the loudness of the telegraphone, so that at present it is not at all comparable in that respect with the various mechanical talking machines in use.

Some premonition of this trouble was felt by me in the early days of the invention when I mentioned in the 14th paragraph of the Caveat, and in the Electrical World article the need of some intensifying apparatus which yet remained to be invented. It is earnestly to be hoped that some investigator will find how to make these machines reproduce sounds with any desired loudness without marring the soft purity of tone which they possess in common with the telephone, and which it is not likely can be attained by any of the mechanical types of phonographs.

Among the interesting features of both the wire and disk telegraphones, is the facility with which a record may be entirely wiped off by passing an ordinary direct current electro-magnet over the wire or the surface of the disk. This can easily be done in the same machine that acts as both recorder and reproducer.

Another very valuable feature of the telegraphone is its capability of reproducing the message in the machine itself or through a telegraph or telephone wire of any

practical length. Thus, long distance telephone messages might be recorded at one or both ends of the line.

Among other ingenious applications of this machine in its wire record form is the reproducing of a message in duplicate so as to send it to several points at the same time -- as, for instance, to a number of train-dispatchers at various stations along a line of railway. This is done by letting the record wire run between two reels far enough apart to permit of a number of receiving magnets being placed against it. In such cases where no permanent record is required the wiping-off magnet can also work at the same time, being placed so as to come into action after the receiving magnets.

Such telephonic uses of the instrument, beyond its mere functions as a phonograph, were indicated in the very name given it in the Caveat, and in the description there given, and were also mentioned and illustrated in the publication in the Electrical World above referred to.

Oberlin Smith.

Bridgeton, New Jersey,
October, 1911

Emile Berliner: *The Development of the Talking Machine. Read before the Franklin Institute of Philadelphia, May 21, 1913; excerpt. Reprinted in "Roll Back the Years - History of Canadian Recorded Sounds and its Legacy: Genesis to 1930"* by Edward B. Moogk, National Library of Canada, Ottawa, 1975; Appendix A, p. 379

the transmission, recording and reproduction of speech, but its ultimate development into as perfect and practical an apparatus as the mechanical talking machines appears to be precluded by the existing conditions.

The Development of the Talking Machine.

By Emile Berliner.

(...) Before closing this paper mention should be made of that very ingenious device, the telegraphone, developed by Mr. Poulson <sic> of Denmark. In this instrument telephone sound waves are made to record themselves as localized magnetic fields of different lengths and intensities in a steel wire, on a steel tape or as a spiral record on a steel disc. In the reproduction these magnetic fields, by passing in touch with a small electro-magneto <sic>, cause electric undulations corresponding to the original sound waves in the helix of this magnet. The circuit of the helix includes a telephone receiver which then emits the sounds originally spoken into the telephone transmitter.

Beautiful as this system appears to be, it suffers from the inherent fault that you cannot confine a localized magnetic field representing a sound wave as you can define a mechanical record of the same. As a consequence articulation is impaired because the magnetic halo of one wave superimposes the halo of the next and this is fatal to those delicate overtones which form the essential characteristics of most consonants. To remedy this the linear speed of the record was increased, but it then became cumbersome on account of too great length and it still showed losses in articulation because of the several electro-magnetic transformations which are embodied in this system.

Magnetic fields were long ago localized in the well-known experiment of writing with a magnet on a piece of steel and then strewing iron filings over it when the writing appeared as line of iron filings which stuck to the magnetic tracings. The first who proposed to apply this principle to the recording of sound by fixing telephone undulations on a steel ribbon or wire and cause such a magnetic record to induce telephonic undulations by electro-magnetic impulses and reproduce the original sound, was Mr. Oberlin Smith, now of Bridgeton, N.J., who published this idea in a prominent electrical journal several years before the advent of the telegraphone. Mr. Smith himself, however, did not carry the plan into successful execution and I do not know when he took up and successfully completed the telegraphone.

The instrument remains today a beautiful combination of electrical and magnetic phenomena as applied to

60

N.N., Biographical sketch of Oberlin Smith, The National Cyclopaedia of American Biography, Vol. 12, page 461, James T. White & Co., New York, N.Y. 1904

SMITH, Oberlin, mechanical engineer, was born in Cincinnati, O., Mar. 22, 1840, son of George R. and Salome (Kemp) Smith. He is first cousin of Robert Longsdon, partner of Sir Henry Bessemer, and co-inventor of the Bessemer process of steel manufacture. Both his parents were natives of England, and his father was a leader in the early anti-slavery work of the then west with Salmon P. Chase and others. He was educated in the public and technical schools of Cleveland and Philadelphia and at the West Jersey Academy in Bridgeton. His taste and inclination were for practical mechanics, in which he showed much skill, and in 1863 he established a machine shop at Bridgeton, N.J., which became known in 1877 as the Ferracute Machine Co., of which Mr. Smith has been continuously president and mechanical engineer. The company is engaged in the Manufacture of various forms of machinery, including many of his own inventions. He has made a specialty of presses for working metals, having designed over five hundred kinds and sizes, always giving especial attention to the development of artistic forms in combination with simplicity, and with massive strength were required. Among his patented inventions are: Cutting, punching, drawing and coining presses (eight patents); drilling machines (three patents); looms (ten patents); aerating apparatus (two patents); soldering machines (two patents); a dump-cart, a drink mixer, a pill-compressor, an automatic egg-boiler, a speed-indicator, a spring-cotter, a decimal wire-gauge (two patents), and a keyless system of locks which can be worked silently in darkness as well as in light. He was also an original inventor of the magneto-electric phonograph, having filed a caveat upon the same in 1883 (sic). Having later made public his ideas he was debarred from a patent, but the invention has recently been taken up in Sweden (sic) and developed into commercial shape. Mr. Smith is the author of "If Material, Why Mortal?" (1887), a religious essay; "Press Working Metals" (1897), an authority upon the principles and practice upon shaping metals in dies by the action of presses; "Technique of Machine Design" in manuscript and numerous technical papers for magazines. He is a member of the American Society of Mechanical Engineers, of which he was president in

1889; of the Engineers Club of New York, the American Institute of Mining Engineers, and an associate of the American Institute of Electrical Engineers. He was married Dec. 25, 1876, at Bernardston, Mass., to Charlotte E., daughter of Georges T. and Frances Hill, formerly of England, and has one son, Percival Hill, and one daughter, Winifred Hill Smith.

¹⁰ *N.N., Biographical sketch of Oberlin Smith, "Who was Who in America", Vol. 1, p. 1147, The A.N. Marquis Co., Chicago 1943*

SMITH, Oberlin, engineer; b. Cincinnati, O., Mar. 22, 1840; s. George R. and Salome (Kemp) S.; ed. W Jersey Acad., Bridgeton, N.J., 1859, Poly Inst., Phila., etc.; stud. engring.; m. Charlotte Hill, Dec. 25, 1876; children- Winifred Hill, Percival Hill. Started, 1863, business which became Ferracute Machine Co.; invented and designed its standard products. Awarded about 70 patents upon mech. inventions. N.J. commr. to Pan-Am. Expn., 1901. Contrb. to engring. jous. and procs. Took active interest in Anti-Slavery cause, later in Y.M.C.A. and woman suffrage. Home: Bridgeton, N.J. Died July 18, 1926.

Chronology of Events

March 22, 1840: Oberlin Smith born in Cincinnati, Ohio, USA

1862 Valdemar Poulsen born

February 14, 1876: Alexander Graham Bell receives U.S. Patent 174,465 for the telephone

End of 1877 / Beginning 1878: Smith learns of the invention of magnetic sound recording by T. A. Edison: "... in an early acquaintance with Mr. Edison he showed me his recently invented phonograph ...

I presently acquired one of these phonographs ..." [22/70]

April 5, 1878: Article in the "Bridgeton Chronicle": Two Great Inventions on the inventions of the telephone and the phonograph: "A combination of the two great inventions may, in time, make it a common experience for one to send a message by Telephone and preserve it by Phonograph ..."

about April 30, 1878: Smith invents improvements for the Edison phonograph, without initially getting away from magnetic sound recording.

between April 30, and September 23, 1878: Smith outlines the possibility of magnetic sound recording on a magnetizable medium of tempered steel which is magnetized by a *short* helix. Playback by means of induction. Advantages: cheap, simple, "delicacy".

September 23, 1878: Smith files two memoranda with the County Clerk of Cumberland County (improvements in mechanical sound recording and invention of magnetic sound recording).

October 4, 1878: Oberlin Smith draws up a "Caveat" for the United States Patent Office (the US \$10) to a certain extent as a preliminary stage for a patent application on an Electric Phonograph or Recording Telephone, which deals exclusively with magnetic sound recording. It is more precise and more extensive than the memorandum of September 23, 1878; the technical content is beyond the publication in *The Electrical World* of 1888.

November 26, 1878: Smith orders from T.A. Edison "a *button* of mercury-impregnated carbon, similar you use in your carbon telephone" - December 6, 1878: Smith places a renewed order with Edison for one (or two) "carbon buttons" - Dec. 13, 1878: Smith confirms receipt of the two "buttons", Price: US\$ 2.

1878/1888: Development of the spinning machine: pieces of steel wire woven into cotton cords

1887/1888: Fresh activities in mechanical sound recording (Ch. S. Tainter and Emile Berliner)

September 8, 1888: "*Some Possible Forms of Phonograph*" published in *The Electrical World*

September 29, 1888: Reader's letter from Smith in "The Electrical World". Smith explains the elongatedly drawn coil as an error in illustration and refers to his experiments with a single-pole transducer.

1898: Application of the first Poulsen patents

1900: Poulsen presents the phonograph at the international exhibition in Paris.

June 28, 1900: the Examiner of the US Patent Office cites "*Some Possible Forms of Phonograph*" in opposition to Patent Application 661,619.

July 11, 1900: Poulsen's attorney W. A. Rosenbaum contests the relevance of "*Some Possible Forms of Phonograph*" in a reply to the US Patent Office.

November 5, 1900: Smith writes to Mr. Chas. A. Lieb, New York, to register his interests in the further development of the telephonograph.

November 9, 1900: Oberlin Smith turns to the US Patent Office after having been informed of the Poulsen machine by reading about it in newspapers.

January 29, 1901: Smith orders a copy of his Caveat of October 4, 1878 from the US Patent Office.

September 27, 1903: In a fire at Oberlin Smith's Ferracute factory, his experimental magnetic recording equipment is destroyed.

January 15, 1907: US Patent 841,387 for the invention of the vacuum tube by Lee de Forest

December 10, 1907: DC-biasing patented: US Patent 873,083, Inventors: Pedersen and Poulsen

December 23, 1908: The County Clerk of Cumberland County confirms the existence of the two memoranda of September 23, 1878.

December 20, 1910: German Patent 249,142 (R. von Lieben, E. Reisz and S. Strauss): Vacuum tube in amplifier circuit

October 1911: Smith writes his detailed report on his work on magnetic sound to the Franklin Institute

May 21, 1913: Before the Franklin Institute in Philadelphia Emile Berliner describes Oberlin Smith as the first to propose magnetic recording. Berliner leaves the question open as to whether Poulsen depended on Smith.

March 26, 1921: US Patent 1,640,881 for the invention of high-frequency biasing (here only for increasing sensitivity) by Wendell L. Carlson and Glenn W. Carpenter, Washington, D.C.

1921: Oberlin Smith designs the "Autofono", a fully automatic record changer

1924/26: Smith receives two patents for his record changer, the second three weeks before his death.

July 18, 1926: Oberlin Smith dies.

1928: Fritz Pfleumer develops magnetic tape (in the modern sense)

1930/1932: Development of the Marconi-Stille magnetic steel tape recorder in England, the "Stahlton-Bandmaschine" by Dr. S. J. Begun at C. Lorenz in Germany

1932/33: Beginning of cooperation on the "Magnetophon": AEG Berlin builds equipment, BASF Ludwigshafen produces the "Magnetophon tape"

1934: Oberlin Smith's home is destroyed by fire

1935: Presentation of the "Magnetophon" at the Berlin Radio Exhibition with sensational success

1938: German radio puts the "Magnetophon" into operational service; Walter Weber works on quality improvements.

1940, on the 100th anniversary of Oberlin Smith's birth: In experiments, Dr. Walter Weber accidentally discovers quality improvement by high-frequency biasing and introduces it in radio broadcasting

1942 to 1944 (?): Stereo recordings of the Berlin Reichs-Rundfunk-Gesellschaft (German Radio Broadcasting Corporation) on magnetophone tape.

1942: Valdemar Poulsen dies.

1975: Research by James W. Gandy leads to the discovery of copies of the two memoranda and of the Caveat of 1878.

1985: Cox/Malim publish *Ferracute*, a biography of the factory founded by Oberlin Smith.

1985: The reader's letter from Smith to *The Electrical World* of Sept. 29, 1888 is rediscovered.

October 18, 1988: James W. Gandy finds the originals of the two memoranda of September 23, 1878 at the office of the County Clerk of Cumberland County, N.J.